



RemoteMix C+

PORTABLE REMOTE MIXER

FEATURES

- Two XLR Microphone Inputs
- Two 1/4" Headphone Jacks
- RCA Line Input
- RCA Line Output
- Balanced XLR Output
- RJ-11 Jack
- Time Delayed Peak Limiter
- Runs 36 hours on two 9V batteries
- AC adapter included
- DTMF / Pulse Keypad

The RemoteMix C+ is a combined audio mixer, headphone amplifier and telephone hybrid in one. It's perfect for remote broadcasts, sporting events, and field reporting from any location.

Simply plug the RemoteMix C+ into an analog phone line, connect a couple of microphones and headphones, and you're ready to call into the station. Switch the "Phone Line" switch to "Dial/Talk" and you will hear a dial tone. Now dial using the RemoteMix C+ keypad. In your headphones, you will hear a mix of both microphones and the line in jack, as well as the audio coming back from the other side of the phone call. This headphone mix also comes out of the back of the unit on an RCA jack and on an XLR balanced jack, which are adjustable from line level to mic level for PA system or tape deck feeds. The built-in time-delayed peak limiter helps to control transmit levels.

Remote broadcasts over a cell phone? Check out our Daptor One wireless phone adapter. This unique accessory connects between the RemoteMix C+ phone line jack and the 2.5 mm headset jack on your wireless phone.

RemoteMix C+

PORTABLE REMOTE MIXER

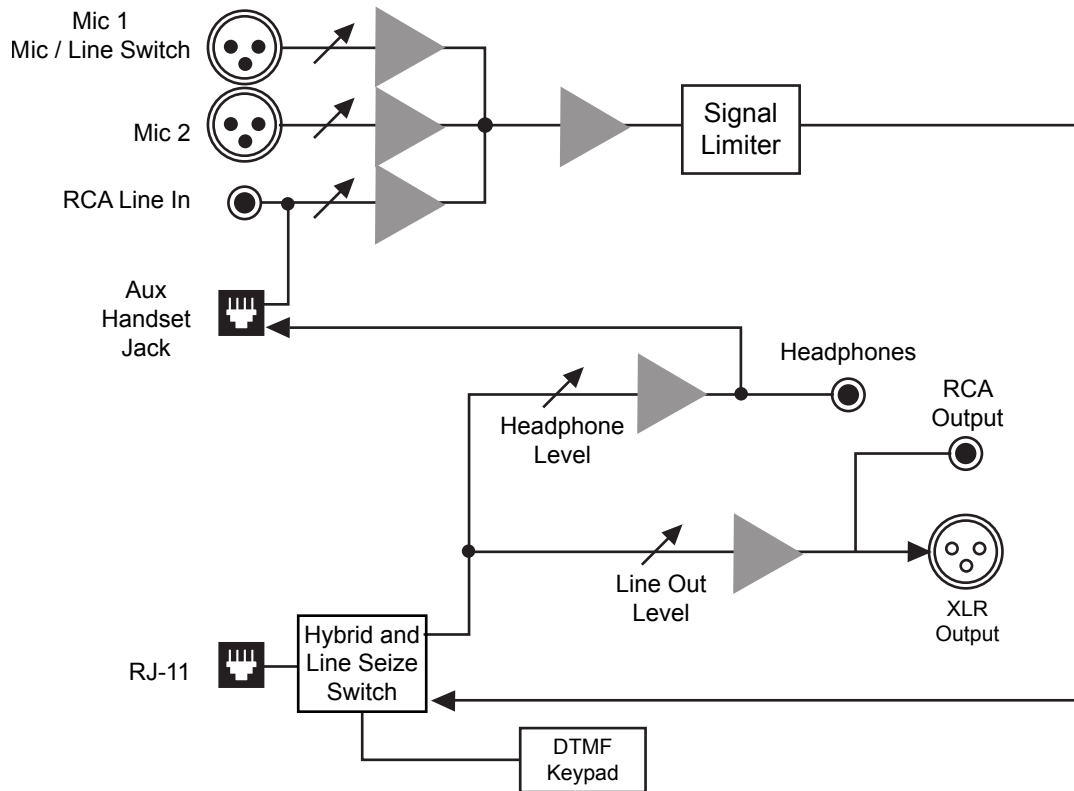

Specifications

	Input	
	Impedence	Level
Female XLR Mics (2)	1 k ohms	15mV RMS (-34 dBu) nom
RCA Line in	50 k ohms	250 mV RMS (-10 dBu) nom

Mic 1 has a Mic/ Line pad switch
Line = +6 dBm nominal

Output		
RCA Line out	—	250 mV RMS (+5 dBu max)
Balanced Male XLR	200 ohms	500 mV RMS (+12 dBu max)
Headphone 1/4" Stereo (2)	8 ohms	1/2 watt per channel

Phone Line Connector:	RJ11C
Ringer:	1.2B REN
Isolation:	1500 VAC
Aux Handset Jack:	biased for electret microphone type handset.
Keypad:	DTMF / Pulse switchable
Size:	6.5" x 4.6" x 2.2" (16.5 x 11.7 x 5.6 cm)
Weight:	1.8 lbs (820 grams)